

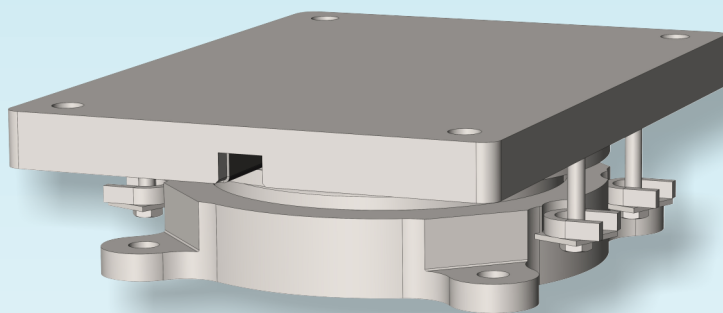

**KE**

Fixed & Sliding Pot Bearings



**Description**

KE series is a range of structural bearings which meets the full requirements of BS EN1337 Parts 1, 2, and 5, and those of the British Department of Transport.

They are manufactured to international quality standards.

The standard range comprises multi-axis rotation bearings in Fixed, Constrained and Free configurations to support loads up to 46000 kN.

**Bearing types**

KE series bearings are available in three forms -

**30KE** Fixed

**31KE** Guided - Free to move in one horizontal direction

**22KE** Free to move in any horizontal direction

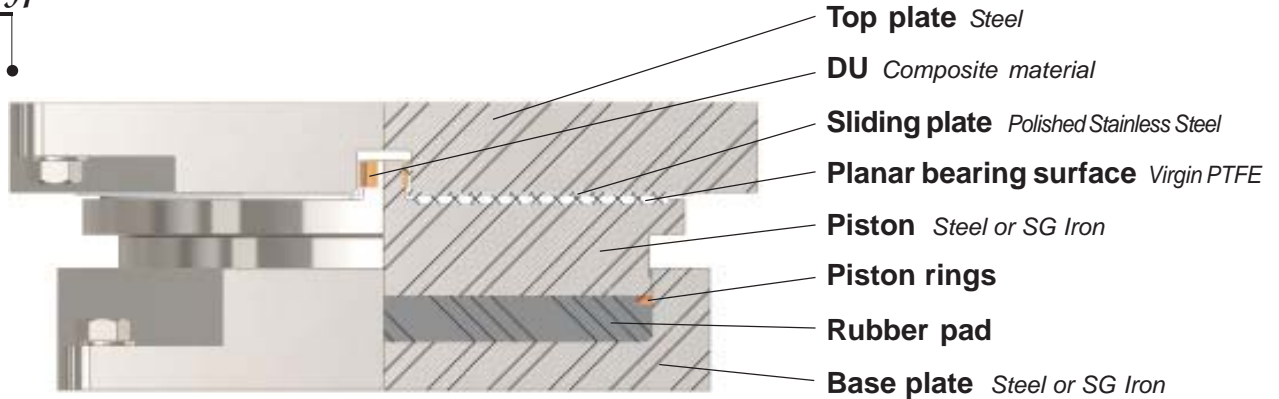
**Typical 31KE details****Attachment**

Fixing holes are provided in the top and base members of the bearings. This enables a variety of fixing methods to be used.

Standard fixings are designed to ensure the bearings can be removed as simply as possible. See page 10.

**Support and Installation**

**Important** - See pages 11 - 14 for Installation and Maintenance.

**We offer a range of installation services** (see examples on page 15).

**Concrete stress**

Where suitable reinforcement of the concrete has been provided the allowable concrete stress is dependent on the relative dimensions of the bearing/structure interface, the total support area and the characteristic strength of the concrete. The stress on the structure should therefore be checked to ensure that it is acceptable.

**Design loads**

The designation of loadings varies depending on the design code applicable. The tables show the capabilities determined in accordance with BS EN 1337.

**Rotation**

Maximum rotation on all our pot bearings range from 0.015 radians for KE0050 to KE1000, and 0.0125 radians for KE1200 to KE3000 respectively.

**Movement**

The dimensions for the **31KE** (Constrained) and **22KE** (Free) bearings are shown in the tables for the following movements -

**Longitudinal**

**31KE** 100mm total  
**22KE** 100mm total

**Transverse**

**31KE** NIL (see page 6)  
**22KE** 40mm total

Additional movements either in longitudinal or transverse directions, depending on bearing type whether it is restraint sliding or free sliding, top plate dimensions will increase accordingly. We will be pleased to advise.

**N.B. 31KE bearings should not be used where movement is required at right angles to the constraints.**

The required movements should be specified in the part number as described below.

The clearance between the constraints must not be used to accommodate any structural movement.

**Designation of part no.**

The part number of a bearing is simply built up as below –

eg.

	Type	Maximum Working Load (kN)	Movement		Fixings	
			Longitudinal (mm)	Transverse (mm)	Top	Base
a	30KE	5000			S	S
b	31KE	5000	100		B	S
c	22KE	5000	100	40	N	B

Full part no for a above is **30KE 500/SS**  
 b above is **31KE 500/100/BS**  
 c above is **22KE 500/100/40/NB**

**Suffix Letters**

By adding a two letter suffix to the bearing part number the type of fixing may be designated -

First letter - Top plate fixing  
 Second letter - Base plate fixing

- N** - No fixings
- B** - Bolts and washers only
- S** - Bolts, washers & sockets

e.g. /BS signifies -  
 B (top plate fixing) Bolts & washers  
 S (base plate fixing) Bolts, washers & sockets

**N.B.** If standard KE series fixings are not used, care should be taken to ensure that bolts can be fitted without dismantling the bearing.

**c** denotes a free KE series Pot Bearing of -

Working load capacity: 5000kN maximum  
 Movement: Longitudinal - 100mm total  
 Transverse - 40mm total  
 Fixing method: No fixings in top plate. Bolts in base plate.

***Bearing design loads***

Bearings should be selected to suit the appropriate design code. The maximum vertical and horizontal loads shown in the tables may be taken in combination.

***Horizontal loading***

The 30KE fixed bearing will resist a horizontal force acting in any direction. In order for the bearing to support the maximum horizontal loads stated in the tables, a minimum concurrent vertical load as shown in the table must co-exist.

Where higher horizontal load capacities are required, special bearings can be offered for such requirements.

We will be pleased to advise.

***Concrete stress***

Where suitable reinforcement of the concrete has been provided the allowable concrete stress is dependent on the relative dimensions of the bearing/structure interface, the total support area, and the characteristic strength of the concrete. The stress on the structure should therefore be checked to ensure that it is acceptable.

Bearing No.	<u>Serviceability Limit State Loads</u>				<u>Ultimate Limit State Loads</u>			Rotation (Radians)
	Maximum Vertical	Permanent	Minimum Vertical	Horizontal	Maximum Vertical	Minimum Vertical	Horizontal	
	(kN)	(kN)	(kN)	(kN)	(kN)	(kN)	(kN)	
30KE0050	653	490	182	102	816	293	136	0.015
30KE0075	940	705	242	146	1175	431	195	0.015
30KE0100	1279	959	317	195	1599	589	260	0.015
30KE0130	1602	1201	408	254	2002	751	338	0.015
30KE0160	2037	1528	492	307	2546	943	409	0.015
30KE0200	2524	1893	594	380	3155	1179	507	0.015
30KE0250	3158	2369	722	473	3948	1477	630	0.015
30KE0300	3758	2819	869	560	4698	1767	747	0.015
30KE0350	4411	3308	990	648	5514	2064	864	0.015
30KE0400	4995	3746	1127	736	6244	2361	981	0.015
30KE0450	5614	4211	1276	819	7018	2628	1092	0.015
30KE0500	6270	4703	1415	902	7838	2945	1202	0.015
30KE0550	6822	5116	1555	985	8527	3208	1313	0.015
30KE0600	7396	5547	1662	1063	9245	3460	1417	0.015
30KE0700	8773	6580	1958	1219	10966	4148	1625	0.015
30KE0800	9925	7444	2211	1365	12406	4695	1820	0.015
30KE0900	11148	8361	2425	1506	13935	5257	2008	0.015
30KE1000	12442	9331	2632	1638	15552	5783	2184	0.015
30KE1200	14826	11119	2969	1886	18532	6715	2515	0.0125
30KE1400	17418	13064	3259	2106	21773	7860	2808	0.0125
30KE1600	19738	14804	3511	2301	24673	8808	3068	0.0125
30KE1800	22203	16652	3754	2471	27754	9814	3295	0.0125
30KE2000	24813	18610	3963	2613	31016	10840	3484	0.0125
30KE2250	27851	20888	4196	2754	34814	11963	3672	0.0125
30KE2500	30000	23299	4221	2852	38831	13105	3802	0.0125
30KE3000	37030	27772	4245	2925	46287	16322	3900	0.0125

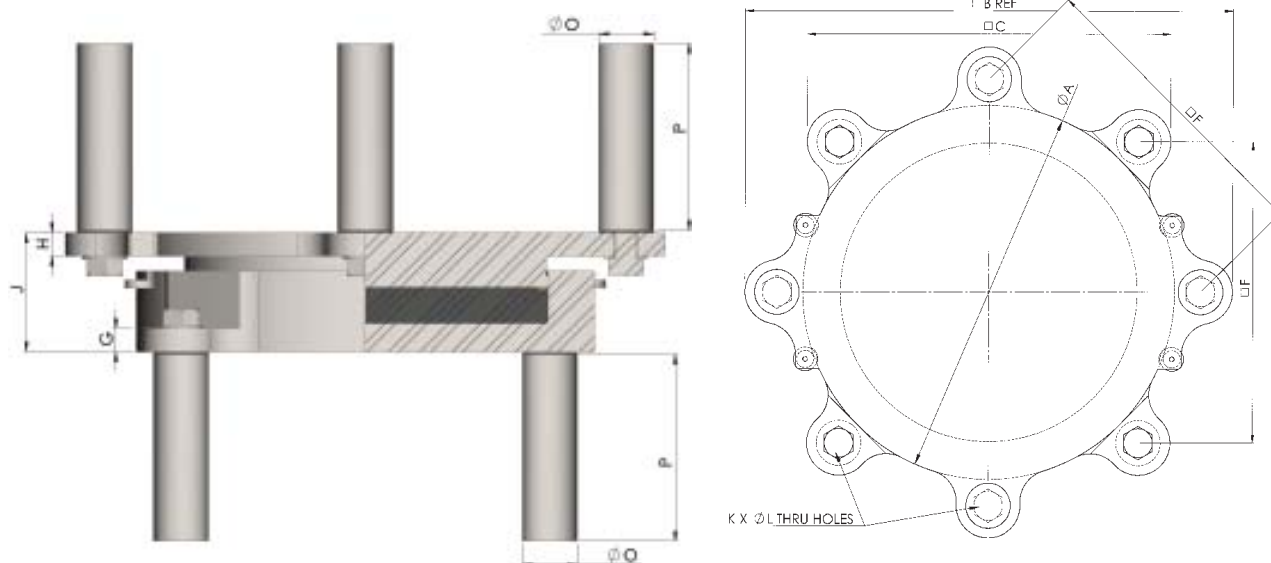

Bearing No.	Installation Dimensions (mm)													Bearing Weight (kg) WT
	A	B	C	F	G	H	J	K	L	M	N	O	P	
30KE0050	190	267	200	160	12	12	66	4	14	30	30	35	110	13
30KE0075	219	295	220	180	12	12	69	4	14	35	35	35	110	17
30KE0100	258	355	265	215	16	16	76	4	18	40	40	40	140	27
30KE0130	293	390	290	240	16	16	80	4	18	40	40	40	140	36
30KE0160	332	428	317	267	16	16	82	4	18	40	40	40	140	46
30KE0200	371	488	362	302	20	20	89	4	22	50	50	50	170	64
30KE0250	419	536	396	336	20	20	92	4	22	50	50	50	170	82
30KE0300	461	597	442	372	24	24	100	4	26	60	60	55	200	108
30KE0350	502	638	471	401	24	24	107	4	26	60	60	55	200	137
30KE0400	534	670	494	424	24	24	111	4	26	60	60	55	200	160
30KE0450	568	740	549	459	30	30	119	4	32	70	70	70	240	196
30KE0500	600	771	571	481	30	30	122	4	32	75	75	70	240	224
30KE0550	632	803	594	504	30	30	124	4	32	75	75	70	240	246
30KE0600	660	832	614	524	30	30	125	4	32	80	80	70	240	270
30KE0700	709	880	648	558	30	30	133	4	32	80	80	70	240	337
30KE0800	752	948	699	599	36	36	145	4	38	90	90	80	300	412
30KE0900	808	1004	739	639	36	36	151	4	38	90	90	80	300	482
30KE1000	852	1048	770	670	36	36	155	4	38	100	100	80	300	560
30KE1200	933	1164	858	738	42	42	166	4	44	110	110	105	360	727
30KE1400	1008	1239	911	791	42	42	173	4	44	110	110	105	360	873
30KE1600	1070	1301	955	835	42	42	178	4	44	120	120	105	360	1007
30KE1800	1130	1396	1028	888	48	48	191	4	50	120	120	120	410	1211
30KE2000	1186	1453	1068	928	48	48	197	4	50	120	120	120	410	1369
30KE2250	1250	1517	1113	973	48	48	204	4	50	120	120	120	410	1558
30KE2500	1312	1579	1157	1017	48	48	209	4	50	120	120	120	410	1781
30KE3000	1426	1692	1237	1097	48	48	218	4	50	120	120	120	410	2123

Note: M = Length of base screw, N = Length of top screw.

For any enquiries or advice, please contact us at [enquiry@ekspan.co.uk](mailto:enquiry@ekspan.co.uk) or call 0114 2611126

EKSPAN - KE SERIES BEARINGS - EN 1337

***Bearing design loads***

Bearings should be selected to suit the appropriate design code. The maximum vertical and horizontal loads shown in the tables may be taken in combination.

***Horizontal loading***

The 31KE guided bearing will resist a horizontal force acting at right angles to the main direction of movement. In order for the bearing to support the maximum horizontal loads stated in the tables, a minimum concurrent vertical load as shown in the table must co-exist. Where higher horizontal load capacities are required, special bearings can be offered for such requirements. We will be pleased to advise.

***Transverse movement***

31KE bearings are designed to accommodate movement in one direction only. Movement transverse to the constraint is nominally zero. In practice the transverse movement is 1mm maximum. Standard 31KE bearings should not be used where movement is required at right angles to the constraint. Special bearings can be offered for such requirements.

***Concrete stress***

Where suitable reinforcement of the concrete has been provided the allowable concrete stress is dependent on the relative dimensions of the bearing/structure interface, the total support area, and the characteristic strength of the concrete. The stress on the structure should therefore be checked to ensure that it is acceptable.

Bearing No.	<u>Serviceability Limit State Loads</u>				<u>Ultimate Limit State Loads</u>			Rotation (Radians)
	Maximum Vertical	Permanent	Minimum Vertical	Horizontal	Maximum Vertical	Minimum Vertical	Horizontal	
	(kN)	(kN)	(kN)	(kN)	(kN)	(kN)	(kN)	
31KE0050	653	490	297	102	816	293	136	0.015
31KE0075	940	705	424	146	1175	431	195	0.015
31KE0100	1279	959	566	195	1599	589	260	0.015
31KE0130	1602	1201	720	254	2002	751	338	0.015
31KE0160	2037	1528	894	307	2546	943	409	0.015
31KE0200	2524	1893	1112	380	3155	1179	507	0.015
31KE0250	3158	2369	1391	473	3948	1477	630	0.015
31KE0300	3758	2819	1656	560	4698	1767	747	0.015
31KE0350	4411	3308	1929	648	5514	2064	864	0.015
31KE0400	4995	3746	2200	736	6244	2361	981	0.015
31KE0450	5614	4211	2446	819	7018	2628	1092	0.015
31KE0500	6270	4703	2732	902	7838	2945	1202	0.015
31KE0550	6822	5116	2982	985	8527	3208	1313	0.015
31KE0600	7396	5547	3207	1063	9245	3460	1417	0.015
31KE0700	8773	6580	3808	1219	10966	4148	1625	0.015
31KE0800	9925	7444	4298	1365	12406	4695	1820	0.015
31KE0900	11148	8361	4791	1506	13935	5257	2008	0.015
31KE1000	12442	9331	5242	1638	15552	5783	2184	0.015
31KE1200	14826	11119	6060	1886	18532	6715	2515	0.0125
31KE1400	17418	13064	7043	2106	21773	7860	2808	0.0125
31KE1600	19738	14804	7869	2301	24673	8808	3068	0.0125
31KE1800	22203	16652	8727	2471	27754	9814	3295	0.0125
31KE2000	24813	18610	9575	2613	31016	10840	3484	0.0125
31KE2250	27851	20888	10506	2754	34814	11963	3672	0.0125
31KE2500	30000	23299	11441	2852	38831	13105	3802	0.0125
31KE3000	37030	27772	12934	2925	46287	16322	3900	0.0125

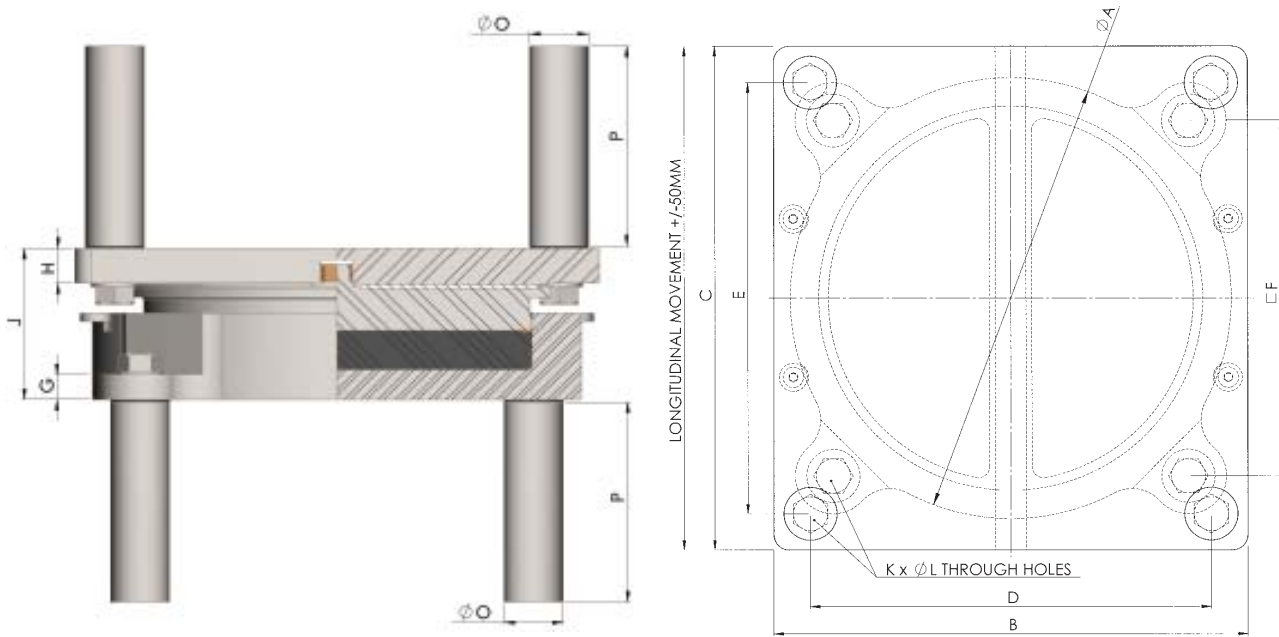

Bearing No.	Installation Dimensions (mm)															Bearing Weight (kg) WT
	A	B	C	D	E	F	G	H	J	K	L	M	N	O	P	
31KE0050	190	230	350	188	308	160	12	32	104	4	14	30	50	35	110	28
31KE0075	219	250	380	208	338	180	12	32	106	4	14	30	50	35	110	35
31KE0100	258	290	405	236	351	215	16	32	108	4	18	40	55	40	140	47
31KE0130	293	325	430	271	376	240	16	33	113	4	18	40	60	40	140	60
31KE0160	332	365	460	311	406	267	16	34	114	4	18	40	60	40	140	76
31KE0200	371	405	485	339	419	302	20	35	118	4	22	50	65	50	170	96
31KE0250	419	460	530	394	464	336	20	37	123	4	22	50	65	50	170	126
31KE0300	461	505	560	427	482	372	24	38	128	4	26	60	80	55	200	155
31KE0350	502	545	585	467	507	401	24	39	136	4	26	60	80	55	200	191
31KE0400	534	575	610	497	532	424	24	40	141	4	26	60	80	55	200	220
31KE0450	568	610	635	514	539	459	30	41	144	4	32	80	90	70	240	252
31KE0500	600	640	660	544	564	481	30	42	148	4	32	80	90	70	240	286
31KE0550	632	675	675	579	579	504	30	43	151	4	32	80	90	70	240	319
31KE0600	660	700	700	604	604	524	30	43	152	4	32	80	90	70	240	347
31KE0700	709	750	750	654	654	558	30	44	161	4	32	80	90	70	240	422
31KE0800	752	795	795	681	681	599	36	46	169	4	38	90	100	80	300	501
31KE0900	808	860	860	746	746	639	36	52	181	4	38	90	110	80	300	633
31KE1000	852	905	905	791	791	670	36	54	187	4	38	90	110	80	300	728
31KE1200	933	985	985	853	853	738	42	61	199	4	44	110	120	105	360	940
31KE1400	1008	1060	1060	928	928	791	42	67	212	4	44	110	130	105	360	1171
31KE1600	1070	1120	1120	988	988	835	42	71	221	4	44	110	130	105	360	1376
31KE1800	1130	1180	1180	1030	1030	888	48	76	233	4	50	120	150	120	410	1624
31KE2000	1186	1240	1240	1090	1090	928	48	77	240	4	50	120	150	120	410	1834
31KE2250	1250	1300	1300	1150	1150	973	48	80	250	4	50	120	150	120	410	2107
31KE2500	1312	1365	1365	1215	1215	1017	48	82	257	4	50	120	150	120	410	2379
31KE3000	1426	1480	1480	1330	1330	1097	48	87	271	4	50	120	160	120	410	2951

Note: M = Length of base screw, N = Length of top screw.

For any enquiries or advice, please contact us at [enquiry@ekspan.co.uk](mailto:enquiry@ekspan.co.uk) or call 0114 2611126

EKSPAN - KE SERIES BEARINGS - EN 1337

***Bearing design loads***

Bearings should be selected to suit the appropriate design code. If in doubt seek our advice.

***Concrete stress***

Where suitable reinforcement of the concrete has been provided the allowable concrete stress is dependent on the relative dimensions of the bearing/structure interface, the total support area, and the characteristic strength of the concrete. The stress on the structure should therefore be checked to ensure that it is acceptable.

Bearing No.	Serviceability Limit State Loads			Ultimate Limit State Loads		Rotation (Radians)
	Maximum Vertical	Permanent	Minimum Vertical	Maximum Vertical	Minimum Vertical	
	(kN)	(kN)	(kN)	(kN)	(kN)	
22KE0050	612	408	198	816	247	0.015
22KE0075	881	588	214	1175	267	0.015
22KE0100	1199	800	289	1599	361	0.015
22KE0130	1502	1001	366	2002	458	0.015
22KE0160	1910	1273	467	2546	584	0.015
22KE0200	2366	1578	574	3155	717	0.015
22KE0250	2961	1974	709	3948	887	0.015
22KE0300	3524	2349	837	4698	1046	0.015
22KE0350	4136	2757	970	5514	1213	0.015
22KE0400	4683	3122	1085	6244	1356	0.015
22KE0450	5264	3509	1201	7018	1501	0.015
22KE0500	5879	3919	1338	7838	1672	0.015
22KE0550	6395	4264	1452	8527	1815	0.015
22KE0600	6934	4623	1569	9245	1961	0.015
22KE0700	8225	5483	1858	10966	2322	0.015
22KE0800	9305	6203	2097	12406	2621	0.015
22KE0900	10451	6968	2351	13935	2939	0.015
22KE1000	11664	7776	2619	15552	3274	0.015
22KE1200	13899	9266	3049	18532	3811	0.0125
22KE1400	16330	10887	3550	21773	4438	0.0125
22KE1600	18505	12337	4019	24673	5023	0.0125
22KE1800	20816	13877	4505	27754	5631	0.0125
22KE2000	23262	15508	5030	31016	6288	0.0125
22KE2250	26111	17407	5624	34814	7030	0.0125
22KE2500	29123	19416	6264	38831	7830	0.0125
22KE3000	34715	23144	7434	46287	9293	0.0125



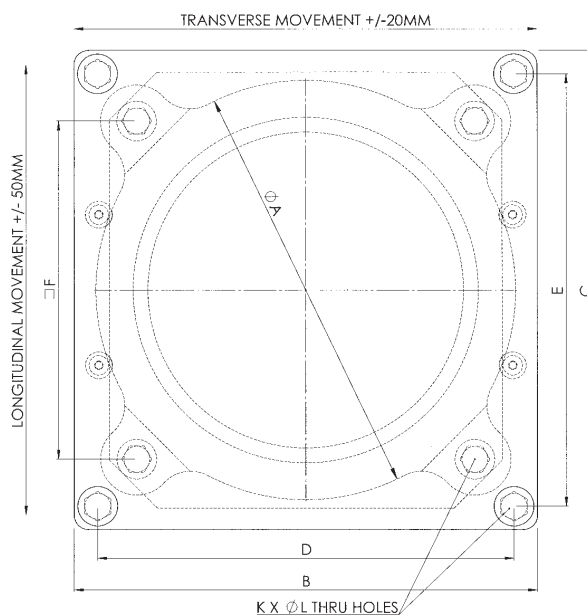
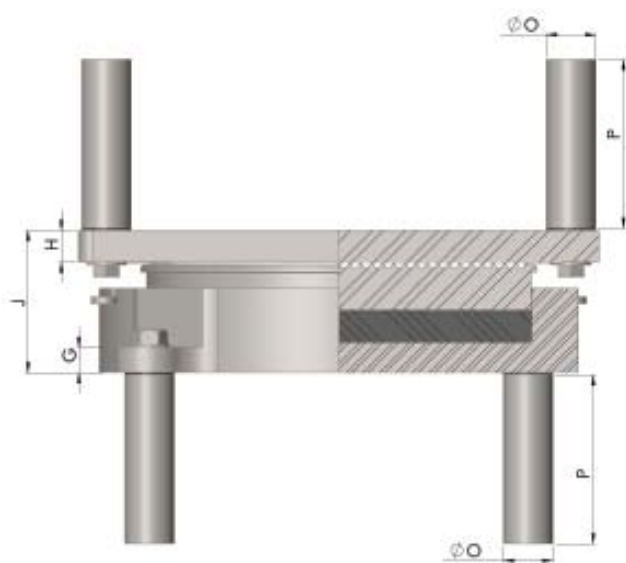

Bearing No.	Installation Dimensions (mm)															Bearing Weight (kg) WT
	A	B	C	D	E	F	G	H	J	K	L	M	N	O	P	
22KE0050	190	247	307	212	272	160	12	16	74	4	14	30	35	35	110	19
22KE0075	219	274	334	239	299	180	12	18	79	4	14	30	40	35	110	26
22KE0100	258	302	362	257	317	215	16	20	84	4	18	40	45	40	140	36
22KE0130	293	330	390	285	345	240	16	24	92	4	18	40	50	40	140	50
22KE0160	332	364	416	319	371	267	16	28	98	4	18	40	50	40	140	67
22KE0200	371	400	445	345	390	302	20	31	104	4	22	50	60	50	170	87
22KE0250	419	446	480	391	425	336	20	35	111	4	22	50	65	50	170	117
22KE0300	461	490	518	425	453	372	24	38	118	4	26	60	70	55	200	149
22KE0350	502	529	550	464	485	401	24	41	128	4	26	60	80	55	200	190
22KE0400	534	559	578	494	513	424	24	42	133	4	26	60	80	55	200	219
22KE0450	568	591	608	511	528	459	30	43	136	4	32	70	90	70	240	252
22KE0500	600	621	633	541	553	481	30	45	141	4	32	70	90	70	240	289
22KE0550	632	651	653	571	573	504	30	49	147	4	32	70	90	70	240	333
22KE0600	660	677	677	597	597	524	30	51	150	4	32	70	100	70	240	369
22KE0700	709	723	723	643	643	558	30	52	160	4	32	70	100	70	240	444
22KE0800	752	763	763	668	668	599	36	54	168	4	38	90	110	80	300	523
22KE0900	808	816	816	721	721	639	36	61	181	4	38	90	110	80	300	654
22KE1000	852	857	857	762	762	670	36	63	187	4	38	90	120	80	300	749
22KE1200	933	944	944	834	834	738	42	69	198	4	44	100	130	105	360	963
22KE1400	1008	1014	1014	904	904	791	42	72	208	4	44	100	130	105	360	1166
22KE1600	1070	1072	1072	962	962	835	42	76	217	4	44	100	140	105	360	1367
22KE1800	1130	1129	1129	1004	1004	888	48	78	226	4	50	120	150	120	410	1578
22KE2000	1186	1181	1181	1056	1056	928	48	80	234	4	50	120	150	120	410	1786
22KE2250	1250	1241	1241	1116	1116	973	48	81	242	4	50	120	150	120	410	2030
22KE2500	1312	1300	1300	1175	1175	1017	48	83	249	4	50	120	150	120	410	2287
22KE3000	1426	1407	1407	1282	1282	1097	48	87	262	4	50	120	160	120	410	2813

Note: M = Length of base screw, N = Length of top screw.

For any enquiries or advice, please contact us at [enquiry@ekspan.co.uk](mailto:enquiry@ekspan.co.uk) or call 0114 2611126

EKSPAN - KE SERIES BEARINGS - EN 1337

## Standard Fixings for KE Series Bearings

### KE Series fixings - with socket

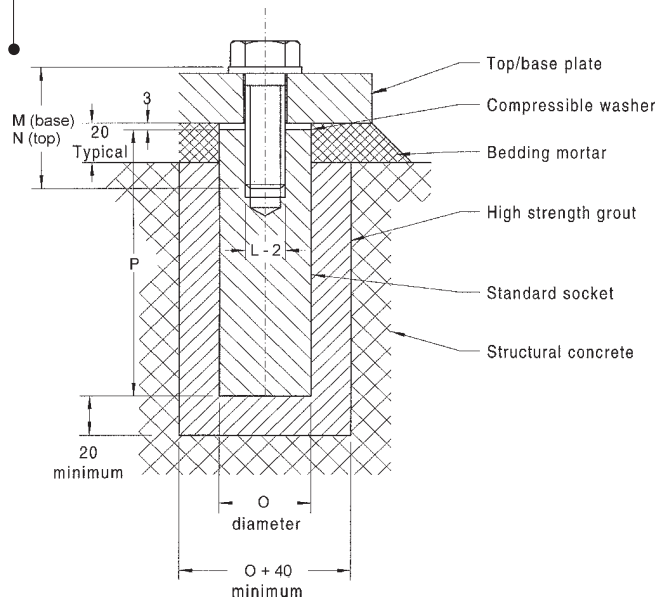

### KE Series fixings - with studs

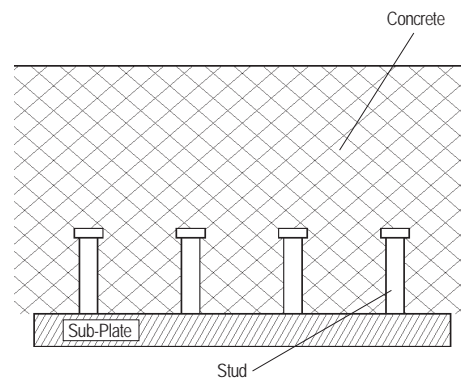

With steel to steel connections bolting or welding of Ekspan sub-plates is possible.

### Notations to dimensional references for bearing diagrams

- |   |  |
|---|--|
| <ul style="list-style-type: none"> <li><b>A</b> - Base plate square dimension</li> <li>- length or breadth of base plate (square dimension - mm)</li> <li><b>B</b> - Width of top plate (mm)</li> <li><b>C</b> - Length of top plate (mm)</li> <li><b>D</b> - Transverse width between the fixings on top plate (mm)</li> <li><b>E</b> - Longitudinal length between the fixings on top plate (mm)</li> <li><b>F</b> - Longitudinal / transverse distance between the fixings on base plate (square dimension - mm)</li> <li><b>G</b> - Lug thickness of base plate (mm)</li> </ul> | <ul style="list-style-type: none"> <li><b>H</b> - Lug thickness of top plate (mm)</li> <li><b>J</b> - Overall height of the nominal bearing (mm)</li> <li><b>K</b> - Hole diameter of the fixings on top and base plate</li> <li><b>L</b> - No. of fixings on top and base plate</li> <li><b>M</b> - Length and breadth of base sub plate (square dimension - mm)</li> <li><b>N</b> - Thickness of base or top sub plate (mm)</li> <li><b>O</b> - Diameter of top/base socket (mm)</li> <li><b>P</b> - Length of top/base socket (mm)</li> </ul> |
|---|--|



**GOOD  
INSTALLATION**

Mechanical guide bearing and upper adaptor plate correctly installed.  
All bearing interfacing surfaces are horizontal.  
All surfaces are free from contaminants.



**BAD  
INSTALLATION**

Bearing incorrectly installed.  
Over rotation due to poor grout bed. Fasteners not tightened. Additional washers used as packers.  
Void between top plate and super structure.  
Stainless steel sliding surface painted on site.

## Installation

### CONSIDER THE EFFECTS IF BEARINGS ARE NOT CORRECTLY INSTALLED

Our structural bearings are manufactured to close tolerances by skilled technicians working in clean conditions. To obtain the requisite performance from bearings it is imperative that they are properly handled at the work site and installed with the same care as when they were assembled in the factory. The following notes will assist those responsible for specifying and supervising the installation of structural bearings.

Please note that Ekspan are able to provide installation, supervision or training of personnel.

**Bearings must be installed with precision to meet the bridge and bearing design criteria.**

## Storage

Our structural bearings are protected from contamination under normal working conditions by an efficient sealing system. Care should be taken in storage to prevent contamination and damage to the working surfaces. Stacking should be avoided where possible.

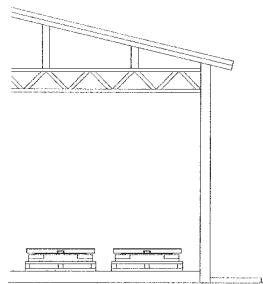

Correct

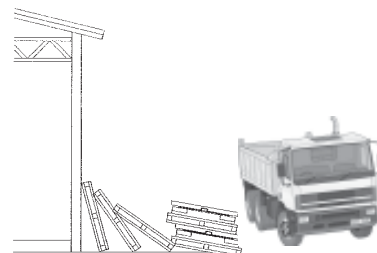

Incorrect

## Handling

Robust transportation devices are fitted to all bearings to ensure that the components are maintained in their correct relative positions before and during installation. The devices are normally finished in red paint. Unless special devices have been specified, they should not be used for slinging or suspending the bearings beneath beams.

Due to unpredictable conditions, which may occur during transportation or handling on site, the alignment and presetting (if applicable) of the assembled bearing should be checked against the drawing. Do not endeavour to rectify any discrepancies on site. The bearing should either be returned to Ekspan or, where practical, an Ekspan engineer should be called in to inspect and reassemble. Bearings too heavy to be lifted by hand should be properly slung using lifting equipment.

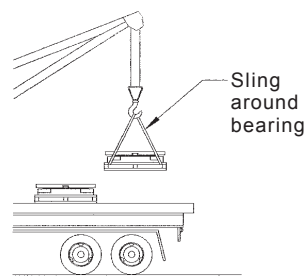

Correct

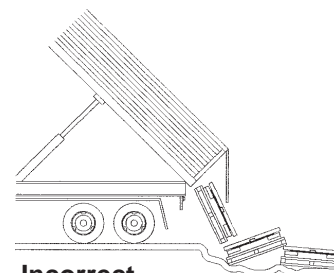

Incorrect

***Presetting***

If bearings are required to be preset eg where once only large movements may occur during stressing operations, this should be specified as a requirement and should only be carried out in our works prior to despatch. It is not recommended to attempt this operation on site.

***Bedding***

Bearings must be supported on a flat rigid bed. Steel spreader plates must be machined flat and smooth to mate exactly with the bearings' upper and lower faces. Bearings may also be bedded on epoxy or cement mortar or by dry packing. Whichever system is preferred for the particular structure it is of extreme importance that the final bedding is free from high or hard spots, shrinkage, voids, etc.

Unless there is a specific design requirement, the planar surfaces must be installed in a horizontal plane. The correct installation of bearings is vital for the bearing performance. Costly repairs become necessary all too often due to inadequate specification or poor site supervision. The bearings should not be loaded until the bedding mortar has cured.

*Fixing bearings to concrete using permanent anchor plates*

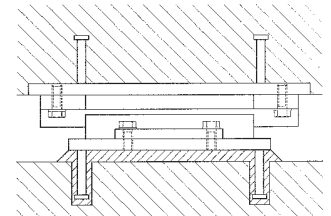

***Cast-in-situ structures***

Care must be taken to ensure that the bearings are not damaged by the formwork or contaminated by concrete seepage. The interface between the top plate and the formwork should be protected and sealed. Owing to the loading effects of a wet concrete mass, the top plates should be propped to prevent rotation and plate distortion. Bearing top plates of PTFE sliding bearings are especially vulnerable in this respect.

*Fixing cast-in-situ structures ensure that the bearing working surfaces are protected and supported to prevent distortion and rotation*

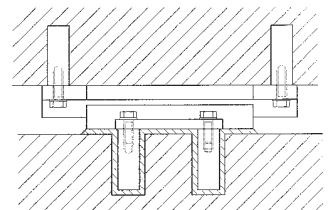

***Bearing removability***

Where possible, bearings should be fixed in such a manner as to facilitate removal. Our bearings have generally been designed with this in mind. However, when selecting the bearing type preferred, the removability feature should be highlighted in your enquiry.

***Removal of transport brackets***

These brackets, normally painted red should only be removed when the bearing is properly installed and ready for operation.

## Check list for the installation of bearings

### DO-

1. Handle carefully and where necessary with adequate craneage.
2. Store in a clean dry place.
3. Ensure that the bearings are installed in the correct location and orientation.
4. Ensure that the bearings are installed on a flat rigid bed before the design loads are applied.
5. Ensure that the fixings are uniformly tightened.
6. Complete any site coatings and make good paint damaged during handling and installation.
7. Protect working surfaces during the placing of in-situ concrete.
8. Keep the bearings and surrounding areas clean.
9. Remove any temporary transit clamps etc. before the bearings are required to operate.
10. Take special care to support top plates when casting in-situ concrete.

### DO NOT-

1. Dismantle the bearing on site.
2. Leave bearings uncovered.
3. Attempt to modify without our approval.
4. Install without qualified supervision.

## Site Coating

Care should be taken to ensure that working surfaces are not damaged in any site coating operation. After installation damaged coatings must be repaired irrespective of any call for site coatings. Exposed fixing bolts should be protected after final tightening. Any tapped holes exposed after removal of transportation brackets etc. (coloured red) should be sealed with self-vulcanizing silicone sealant.

## Routine maintenance of bearings

1. Immediately following installation bearings shall be inspected to ensure that all aspects of 'Installation of bearings' have been adhered to and bearings shall subsequently be re-inspected not less frequently than every two years after their installation.
2. Paint and /or other specified protective coatings must be maintained in good and efficient condition and free from scratches or chips. Any areas of the protective coating showing damage or distress must be rectified.
3. Areas surrounding the bearings must be kept clean and dry and free from the adverse effects of external influences such as airborne debris or water/salt (for example emanating from leaking joints).
4. The wearing surfaces of the bearing must be checked to ensure that they are continuing to operate efficiently.
5. Fixing bolts must be checked for tightness.
6. Any bedding material showing signs of distress or ineffectiveness must be replaced and the reason for its failure investigated and corrected.
7. Routine inspections shall include a check that translational and rotational capacities of the bearing have not been exceeded and show no sign of being likely to exceed the requirements specified at the design stage.

*Sample Quality Bearing Specification Clauses - KE Series Pot Bearings*

- 1.01 The bearings should be designed in accordance with EN1337 and be constructed from steel grade EN100025 S355 J2.  
*(HIGH QUALITY STEEL GOOD LOADING CAPACITIES)*
- 1.02 Bearings should be designed to allow for combination load effects.
- 1.03 The sliding surface of the bearing must be fully welded to the top plate of the bearing. This prevents crevice corrosion de-lamination of the stainless steel ensuring bearing longevity. The stainless steel sliding surface should be in accordance with EN 10088-2 1.4401 + 2B or 1.4404 + 2B. Surface treatment roughness Ry5i shall not exceed 1 µm in accordance with EN ISO 4287, and the hardness shall be in the range 150 HV1 to 220 HV1, according to EN ISO 6507-2. Paint will be applied to overlap the welded area of the sliding surface so as to protect the area from the risk of corrosion.  
*(REDUCES CORROSION IN UNLOADED AREAS WHICH IS THE CAUSE OF MOST BEARING FAILURES)*
- 1.04 PTFE bearing surfaces shall be Virgin material with a dimpled surface and lubricated with silicon grease in accordance with EN1337-2. The PTFE shall be retained in the bearing by a machined recess.  
*(FRICTION IS AT A MINIMUM, LIFE IS EXTENSIVE AND THE PTFE CANNOT "CREEP")*
- 1.05 Guide sliding surfaces should also be fully welded and mirror polished. The wear surface of the guide shall be a mechanically restrained high load resistant material DU(B) in accordance with EN1337-2.  
*(THE LIFE OF BEARINGS IS EXTENDED WITH USE OF GOOD WEAR MATERIALS)*
- 1.06 Pot bearing pistons are machined with a tightly controlled tolerance between the pot and the piston.  
*(REDUCE EDGE PRESSURE EFFECTS ON RUBBER)*
- 1.07 The rubber pad in a pot bearing is to have a minimum of 2 brass rings, which should be sized to meet and fit tight to the pot wall. EN1337-5  
*(THIS IS KEY TO ENSURE THAT THE RUBBER IS RETAINED IN THE POT - IF NOT THEN THE RUBBER MAY EXTRUDE UNDER LOAD)*
- 1.08 The rubber pad shall meet EN 1337-5 and be natural rubber or polychloroprene rubber in accordance with ISO 6446. It will be preformed with a recess on the to surface which allows the retaining rings to finish flush with the rubber.  
*(THIS MEANS THAT WHEN THE BEARING IS LOADED THERE ARE NO AIR GAPS TO CLOSE ENSURING THAT DATUMS ARE MAINTAINED)*
- 1.09 The rubber pad shall fit in the pot without need for deflection. Corners should be moulded in such a way as to ensure that the pad fits to the machined pot base.  
*(THIS ALSO REDUCES AIR ENTRAPMENT)*
- 1.10 The outer surfaces of the bearing will be blasted to SA 2½ and have the contract specified paint system applied.
- 1.11 Bearings to be supplied with Ekspan plates. Bearings will be supplied with base and top sockets.

**Ekspan advise that the specification clauses above demonstrate good practice to ensure good quality bearings.**

Notes

CONVERSION TABLE

METRIC

Length	1 mm	=	0.03937 in
	1 m	=	3.281 ft
	1 m	=	1.094 yd
Area	1 mm <sup>2</sup>	=	0.00153 in <sup>2</sup>
	1 m <sup>2</sup>	=	10.764 ft <sup>2</sup>
	1 m <sup>2</sup>	=	1.196 yd <sup>2</sup>
Force	1 N	=	0.2248 lbf
	1 kN	=	0.1004 tonf
Stress and pressure	1 N/mm <sup>2</sup>	=	145 lbf/in <sup>2</sup>
	1 N/mm <sup>2</sup>	=	0.0647 tonf/in <sup>2</sup>
	1 N/m <sup>2</sup>	=	0.0208 lbf/ft <sup>2</sup>
	1 kN/m <sup>2</sup>	=	0.0093 tonf/ft <sup>2</sup>

IMPERIAL

Length	1 in	=	25.4 mm
	1 ft	=	0.3048 m
	1 yd	=	0.9144 m
Area	1 in <sup>2</sup>	=	645.2 mm <sup>2</sup>
	1 ft <sup>2</sup>	=	0.0929 m <sup>2</sup>
	1 yd <sup>2</sup>	=	0.8361 m <sup>2</sup>
Force	1 lbf	=	4.448 N
	1 tonf	=	9.964 kN
Stress and pressure	1 lbf/in <sup>2</sup>	=	0.0068 N/mm <sup>2</sup>
	1 tonf/in <sup>2</sup>	=	15.44 N/mm <sup>2</sup>
	1 lbf/in <sup>2</sup>	=	47.88 N/m <sup>2</sup>
	1 tonf/ft <sup>2</sup>	=	107.3 kN/m <sup>2</sup>

Examples of KE series bearing supply and installation

**M6 DUNAÚJVÁROS SZEKSZÁRD ÉPÍTÉSI KÖZKERESETI TÁRSASÁG - BUDAPEST**

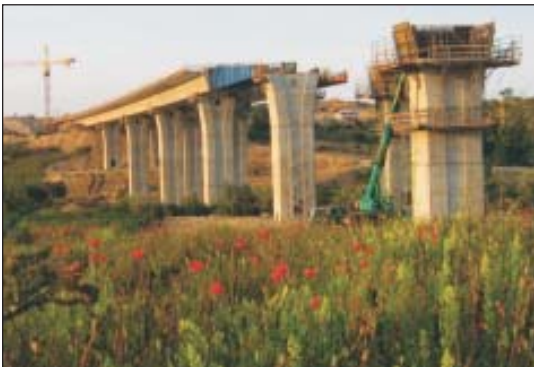

**Job Brief**

**Supplied:** 56 no. KE series pot bearings

These bearings have vertical load capacities from 500 ton to 1200 ton and had to be designed for movements in excess of 0.5 metres to accommodate both the initial installation and the normal in service movements.

**Main Contractor:** M6 Tolna Consortium  
(Bilfinger Berger/Porr/Egis)

**Structure:** Bridge 993 – 630m launch

**SKOVDIGET PROJECT - COPENHAGEN - 6767**



**Job Brief**

**Supplied & Installed:** 26 no. KE series pot bearings

The scope of works comprised of installing temporary jacking structures around the bridge columns, and bearing installation working at a height of approximately 4 metres using portable scaffolding towers.

**Main Contractor:**  
E. PIHL & SØN A.S.  
HauCon A/S



## BRIDGE & INDUSTRIAL BEARINGS



**B Series** Sliding Bearings  
with elastomer base

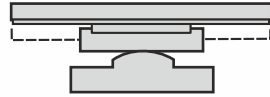

**D Series** Line Rocker Bearings



**EA Series** Sliding Bearings

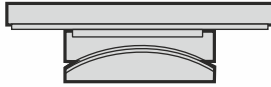

**E Series** Anticlastic Bearings



Elastomeric Bearings

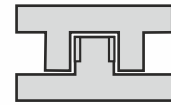

**F & FE Series**  
Pin and Guide Bearings



**G & GE Series**  
Spherical Bearings



**K & KE Series** Pot Bearings

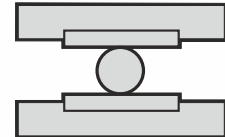

**J Series** Roller Bearings

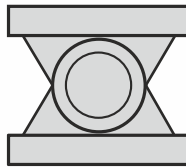

Link Bearings

## EXPANSION & SEAL TYPE JOINTS



Multi Element Expansion Joints



Roller Shutter Expansion Joints



Finger Type Expansion Joints



TF Expansion Joints



T-Mat Expansion Joints



TF B-75 and TF B-7  
Expansion Joints



Single Element Expansion Joints



EC Seal Expansion Joints



ES Seal Expansion Joints



EW Seal Expansion Joints

*A world wide service offering effective solutions in:-*  
**Inspection • Design • Manufacture • Supply**  
**Installation • Commissioning • Planned Maintenance**

Ekspan warrants that products described in this brochure are free from defects in workmanship and material but unless expressly agreed in writing Ekspan gives no warranty that these products are suitable for any particular purpose or for use under any specific conditions notwithstanding that such purpose would appear to be covered by this publication. Ekspan accepts no liability for any loss, damage or expense whatsoever arising directly or indirectly from the use of their products or recommendations. All business undertaken by Ekspan is subject to their standard conditions of sale, copies of which are available upon request. Ekspan products are subject to continual development and Ekspan reserves the right to make changes in the specification and design of their products without prior notice.

Issue 02 - March 2016

E&OE



Certificate No.: LRO 4008849

Ekspan Limited, Compass Works, 410 Brightside Lane, Sheffield S9 2SP, United Kingdom

Tel: +44 (0)114 2611126 • Fax: +44 (0)114 2611165

E-mail: [enquiry@ekspan.co.uk](mailto:enquiry@ekspan.co.uk) • Website: [www.ekspan.com](http://www.ekspan.com)



Certificate No.: LRO 4008850